

# EuroMaster All Terrain Step Platform FPE-AT 1.2

## Technical Data Sheet

### PROPERTIES

☑ Standards	EN 131-7:2013
⚠ Load Rating	150kg
⚡ Electrical Properties	Non conductive
⚙ Warranty	3 years from date of manufacturing

### MEASUREMENTS

⚖ Weight	22.7kg
↕ Distance Between Rungs	0.300m
◇ Open Height	2.11m
∨ Closed Height	2.30m
⤴ Platform Height	1.15m
⌈ Handrail Height	0.96m above platform
✂ Closed Width	0.23m
⏏ Width with Stabilisers	Extended: 0.98m / Fully Extended: 1.38m
⌆ Number of Steps	4 including platform

### COMPONENTS

A Stiles	Fibreglass: ISO-PE resin with e-glass fibres
B Rungs	Round: Alloy 6060 / Mg 0.35-0.6 / Ti 0.10%
C Feet	TerrainMaster
D Platform Deck	Alloy 5052/5251 / Mg 2.2-2.8 / Ti 0%
E Platform Hooks	Alloy 5083-H116 / Mg 4.0-4.9 / Ti 0-0.15%
F Platform Kickboard	Alloy 5251-H34
G Handrail	Alloy 6463-T6 / Mg 0.3-0.9 / Ti 0%
H Brackets	Alloy 5083-H116 / Mg 4.0-4.9 / Ti 0-0.15%
I Rods and Struts	Alloy 6463-T6 / Mg 0.3-0.9 / Ti 0%
J Spacer	Polyethylene
K Step Plates	Alloy 5052/5251 / Mg 2.2-2.8 / Ti 0%
L Rear Step	Alloy 5052/5251 / Mg 2.2-2.8 / Ti 0%
Rivets	Zinc Plated Low Carbon Steel
Nuts	Plated Mild Steel with gold passivate
Washers	Plated Mild Steel with gold passivate

Product Code	FPE-AT 1.2
Manufacturer's Name	Branach Manufacturing Pty Ltd
Phone Number	+61 3 9761 6633
Certified By (Name, Title)	Matt Reeves Engineer
Last Updated	11/03/2021

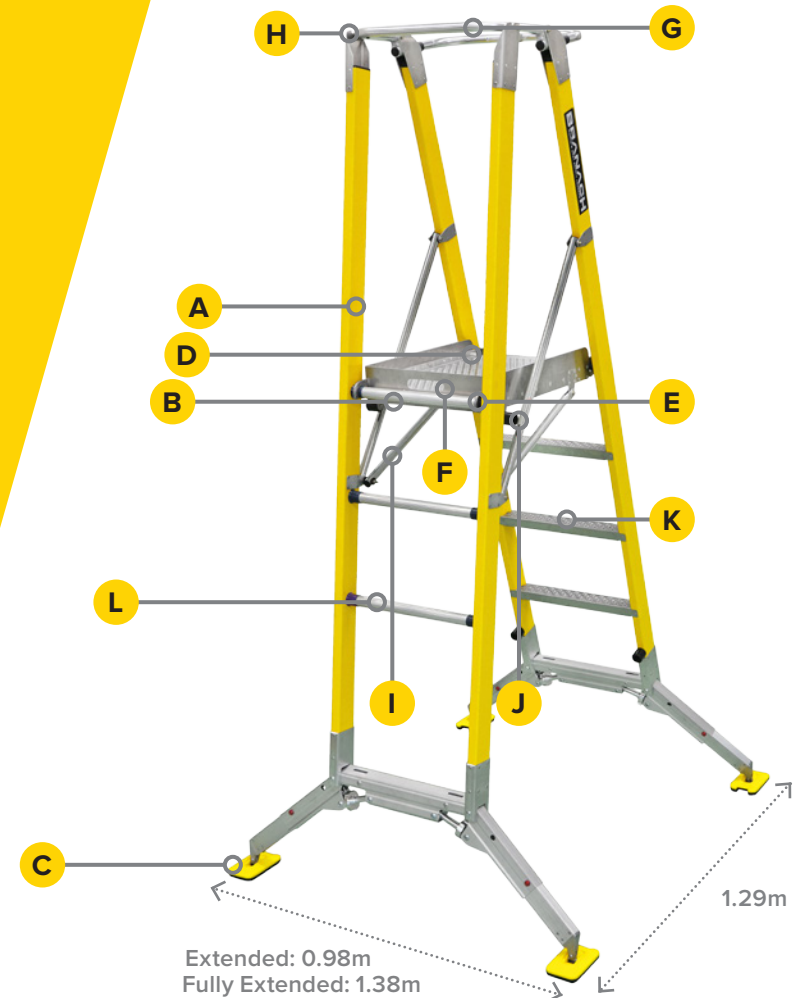

PLEASE NOTE IMAGE IS OF FPE-AT 1.4

# TerrainMaster Safety Stabiliser

## Technical Data Sheet

Product Code	TE
Manufacturer's Name	Branach Manufacturing Pty Ltd
Phone Number	+61 3 9761 6633
Certified By (Name, Title)	Matt Reeves Engineer
Last Updated	11/03/2021

### PROPERTIES

☑ Standards	AS/NZS 1892.3 + EN131
⚠ Load Rating	As per ladder rating
🔧 Warranty	3 years from date of manufacturing

### MEASUREMENTS

⚖ Weight	4kg
----------	-----

### COMPONENTS

<b>A</b> Terrain Master	Alum 6060
<b>B</b> Swivel foot	35% GF Nylon / Poly Urethane Tread
<b>C</b> Legs	Extrusion 6061-T6
<b>D</b> Adjustment wheel	Alum 6061-T6
<b>E</b> Spotting step	Alum 5052
<b>F</b> Swivel joint	Stainless steel
<b>G</b> Quick release legs	Alum 5052
Rivets	Zinc Plated Low Carbon Steel



STORED



LEVELLING



EXTENDED

Extended: 0.98m  
Fully Extended: 1.38m

