

# TerrainMaster TE Extension & Single Ladders

## Safety Stabiliser

### Technical Data Sheet

Product Code	TE
Manufacturer's Name	Branach Manufacturing Pty Ltd
Phone Number	+61 3 9761 6633
Certified By (Name, Title)	Pat Driscoll Business Development Manager
Last Updated	11/03/2021

#### PROPERTIES

☑ Standards	AS/NZS 1892.3
⚠ Load Rating	As per ladder rating
🚫 Chemical Resistance	Tested to AS/NZS 1892.3
☀ Accelerated Weathering Test	Tested to AS 2331.3.1
🛠 Warranty	3 years from date of manufacturing

#### MEASUREMENTS

🏋 Weight	4kg
----------	-----

#### COMPONENTS

<b>A</b> Terrain Master	Alum 6060
<b>B</b> Swivel foot	35% GF Nylon / Poly Urethane Tread
<b>C</b> Legs	Extrusion 6061-T6
<b>D</b> Adjustment wheel	Alum 6061-T6
<b>E</b> Spotting step	Alum 5052
<b>F</b> Swivel joint	Stainless steel
<b>G</b> Quick release legs	Alum 5052
Rivets	Zinc Plated Low Carbon Steel

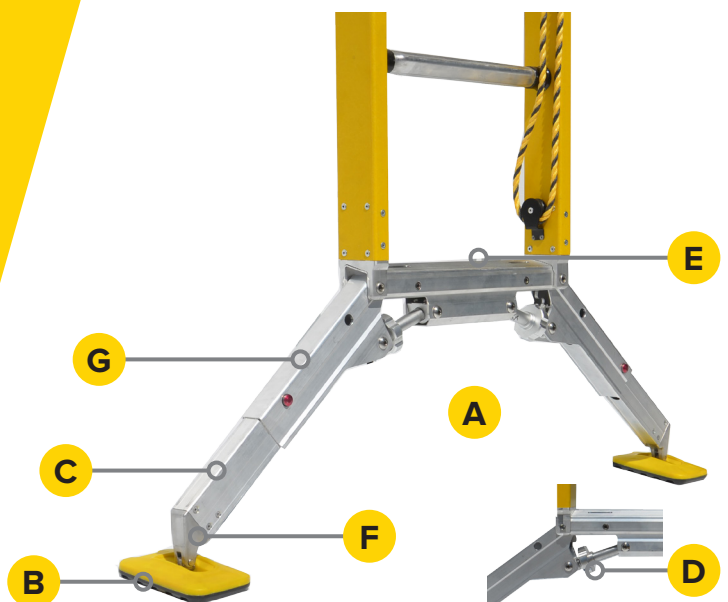
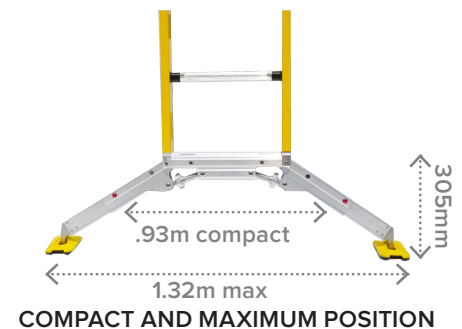
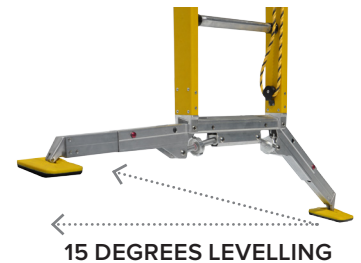

# TerrainMaster TP FPW & FPL Safety Stabiliser

## Technical Data Sheet

Product Code	TP
Manufacturer's Name	Branach Manufacturing Pty Ltd
Phone Number	+61 3 9761 6633
Certified By (Name, Title)	Pat Driscoll Business Development Manager
Last Updated	11/03/2021

### PROPERTIES

<input checked="" type="checkbox"/> Standards	AS/NZS 1892.3
<input checked="" type="checkbox"/> Load Rating	As per ladder rating
<input checked="" type="checkbox"/> Chemical Resistance	Tested to AS/NZS 1892.3
<input checked="" type="checkbox"/> Accelerated Weathering Test	Tested to AS 2331.3.1
<input checked="" type="checkbox"/> Warranty	3 years from date of manufacturing

### MEASUREMENTS

<input checked="" type="checkbox"/> Weight	4kg
--	-----

### COMPONENTS

<b>A</b> Terrain Master	Alum 6060
<b>B</b> Swivel foot	35% GF Nylon / Poly Urethane Tread
<b>C</b> Legs	Extrusion 6061-T6
<b>D</b> Adjustment wheel	Alum 6061-T6
<b>E</b> Spotting step	Alum 5052
<b>F</b> Swivel joint	Stainless steel
<b>G</b> Quick release legs	Alum 5052
Rivets	Zinc Plated Low Carbon Steel

